

**SAILING INSTRUCTIONS**  
**SNIPE CLASS INTERNATIONAL RACING ASSOCIATION USA**  
**SCIRA USA WOMEN'S NATIONAL CHAMPIONSHIP REGATTA**  
**THE US WOMEN'S NATIONALS TROPHY**  
**APRIL 10-11, 2010**  
**FLORIDA YACHT CLUB**  
**Jacksonville, FL**

**Rules:**

- 1.1 The SCIRA USA Women's National Championship Regatta is governed by the rules as defined in the *Racing Rules of Sailing*.
- 1.2 The SCIRA Rules of Conduct for Conducting National and International Championship Regattas (ROC) shall apply.
- 1.3 Any conflict arising between the Deed of Gift and the ROC shall be solved by the application of Deed of Gift.
- 1.4 In case of conflict between the Sailing Instructions and the ROC, the Sailing Instructions shall prevail.
- 1.5 The official language is English. In case of dispute the English text shall prevail.

**Entry and Eligibility:**

- 2.1 This regatta is open to SCIRA registered boats and registered, female Class Member skippers and crews who are in good standing with SCIRA for the current year and (a) currently meet the Deed of Gift trophy restrictions, or (b) are currently registered as a Member of SCIRA in Canada, Mexico, Bermuda, Cuba, Puerto Rico or the US Virgin Islands. No skipper, or crew, shall be eligible to enter, or hull used, unless they are registered in the SCIRA On Line Data Base, or the SCIRA USA Data Base, as paid for the 2010 calendar year.
- 2.2 The same crew shall race in all races, except for reasons satisfactory to the Race Committee. Requests for a change of crew shall be submitted in writing to the Chairman.
- 2.3 Once a crew has been excused, she may not return for the balance of the series.
- 2.4 The Race Committee may inspect competitors, or boats, at any time (while not racing).
- 2.5 The SCIRA Representative may randomly inspect boats during this regatta to ensure the boats comply with the measurement requirements as outlined in the ROC. This modifies ROC 3.3.

**Advertising:**

- 3.1 Advertising is permitted as per Snipe Class rules and ISAF regulation 20.
- 3.2 Boats may be requested to display advertising chosen and supplied by the organizing authority.

**Notices to Competitors:**

- 4.1 Notices to competitors will be posted on the 'Official Regatta Notice Board' located on the patio of the Fleet Center of the Florida Yacht Club.
- 4.2 Any change to the Sailing Instructions will be posted no later than one hour before the first scheduled warning signal for that day, except that any change to the schedule of races will be posted by 1930 hours on the day before it will take effect.
- 4.3 Any change, or amendment, to the Sailing Instructions shall have the prior approval of the SCIRA Representative.
- 4.4 **Competitors Meeting:** There may be a competitors meeting at the Florida Yacht Club Fleet Center at 1015 hours on Saturday, April 10, 2010 which will be announced by two sound signals.

**Signals Made Ashore:**

- 5.1 Signals made ashore shall be displayed from the flagpole on the East Lawn of the Florida Yacht Club and announced by sound signals per RRS Racing Signals.
- 5.2 When Flag "AP" is displayed ashore, "1 minute" is replaced with not less than 45 minutes after the "AP" is lowered.
- 5.3 When Flag "D" is displayed, means: "Boats are not allowed to leave the harbor/shore until the flag is removed". The warning signal will be made not less than 45 minutes after the "D" Flag is lowered.

**Schedule of Races:**

<u>Day and Date</u>	<u>Time of First Warning Signal for Day</u>
Sat, April 10, 2010	1125 hours, additional races to follow
Sun, April 11, 2010	925 hours, additional races to follow

- 6.1 The Race Committee shall attempt to complete five (5) races. Two (2) races shall constitute a Regatta. This changes ROC 4.
- 6.2 Up to four (4) races per day may be sailed. This changes ROC 4.1.
- 6.3 On the last day of the regatta no warning signal will be made after 1300 hours.

**Racing Area:**

- 7. The Racing Area location is the St Johns River immediately east of the Florida Yacht Club

**Courses:**

- 8.1 Courses used shall be one or more of those shown in the Course Diagrams below and are described in detail herein. Sections 8.5 and 8.6 describe the use of offset marks. Note, the use of offset marks is at the discretion of the RC and thus they are not included in the course diagrams below.

An "Olympic Course", signaled by Flag "O" (red and yellow) consisting of a triangle followed by a windward, leeward and windward leg finishing at mark #1.

A Triangular Course, signaled by Flag "T" (red, white and blue vertical stripes) consisting of TWO triangles followed by one windward leg finishing at Mark #1.

A Windward and Leeward Course, signaled by Flag "W" (concentric blue, white and red squares) consisting of a windward and leeward legs, twice around, followed by a windward leg and finishing at Mark #1.

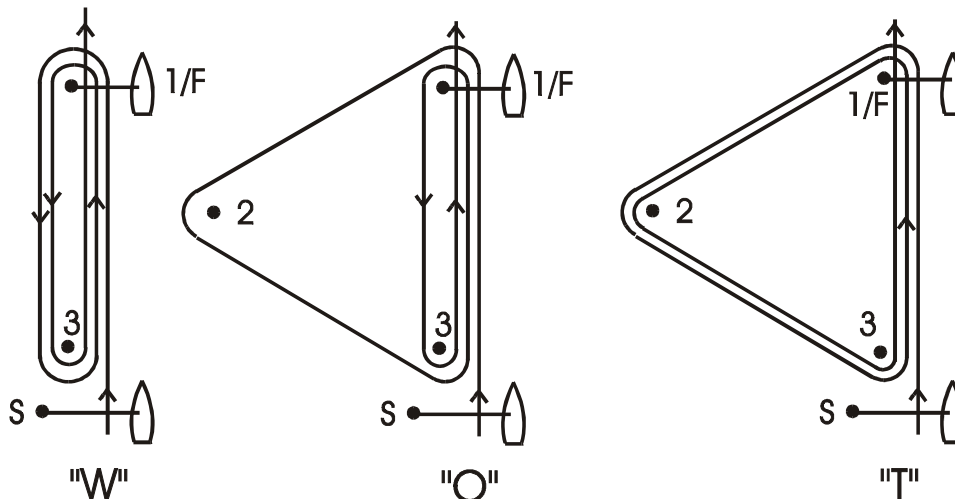

- 8.2 The course diagram indicates the order in which marks are to be passed, or rounded, and the side on which each mark is to be left.
- 8.3 The approximate compass bearing to Mark 1 shall be displayed by numerical posting on a board on the Race Committee Signal Boat before the Warning signal.
- 8.4 Courses will not be shortened, but the length of the course may be modified per RRS 33 and SI 13.2. This changes RRS 32.
- 8.5 An offset mark may be set adjacent to Mark 1 (windward) beginning with leg(s) 5 of the Olympic Course and legs 2 and 4 of the Windward Leeward Course. The Race Committee may remove, without signal, an offset mark prior to the lead boat rounding the adjacent primary, or new mark.
- 8.6 The use of an offset mark shall be indicted by the display of Flag “F” (red diamond on white field) under the Course Flag “O” or “W” before the warning signal.

**Marks:**

- 9.1 Marks 1, 2, 3 shall be four foot (4') orange tetrahedrons.
- 9.2 New marks used in accordance with Change of Course after the Start will be four foot (4') yellow tetrahedrons.
- 9.3 The starting mark will be a four foot (4') orange tetrahedron.
- 9.4 The offset mark will be a two foot (2') tetrahedron.

**The Start:**

- 10.1 The starting line shall be between the staff from which an orange flag is displayed on the Race Committee Signal Boat at the starboard end and the course side of the port end starting mark.
- 10.2 Races will be started in accordance with RRS 26.
- 10.3 The official Class Flag shall be the Snipe Class flag, a red Snipe on a white background.
- 10.4 Mark 3 is not a mark of the course on the first leg of the race.

**Reporting at Starts:**

- 11.1 Before the warning signal of **THE FIRST RACE OF THE DAY** that a boat races, each boat is required to sail past the stern of the Race Committee Signal Boat on starboard tack and verbally check in.
- 11.2 When the Race Committee verbally acknowledges a boat's sail number the check-in has been officially noted.
- 11.3 Any boat failing to check in accordance with instructions 11.1 and 11.2 will receive a scoring penalty equal to 10% of the starters in the first race of the day.

**Recalls:**

- 12.1 RRS 30.3 ('Black Flag Rule') shall not be used.
- 12.2 In the event of an individual recall boats on Course Side will not be hailed.

### **Change of Course After the Start:**

- 13.1 Any mark to be rounded after rounding the new (changed) mark may be relocated to maintain the correct course configuration. When in a subsequent change of course a new mark is replaced, it will be replaced with a primary type of mark.
- 13.2 RRS 33 and ROC 5.3 are modified so that after the first leg of the course is sailed any remaining legs may be shortened or lengthened, provided any leg shortening or lengthening shall not be by more than 30% of the original leg length.

### **The Finish:**

- 14.1 The finish line shall be between the staff from which an orange flag is displayed on an adjacent Race Committee Boat and the course side of the finishing mark.
- 14.2 Flag "R" displayed by a Race Committee boat at the finish means that the Race Committee shall attempt to have another race immediately after the last boat is recorded in the present race.
- 14.3 ROC 10 (Finish Line length) is deleted.

### **Time Limit:**

- 15.1 The races will be managed to last 45-60 minutes for the first boat to finish. This changes ROC 5.1.
- 15.2 The time limit for the first boat to complete the first lap is 30 minutes from the start. If the first boat fails to complete the first lap within 30 minutes the Race Committee shall abandon the race. For the purpose of this Rule a lap means the rounding of Mark 3 for the first time.
- 15.3 The time limit for the first boat to finish the race shall be 1 hour 30 minutes. In addition, any boat failing to finish within 20 minutes after the first boat sails the course and finishes, and said boat is on the course and racing at that time, shall be scored TLE (Time Limit Expired). This changes RRS 35, 63.1, A11, ROC 12, 12.2.

### **Withdrawing From the Race:**

- 16.1 A boat that withdraws from a race or intends not to start a race shall inform any race committee boat at the first opportunity.

### **Protests:**

- 17.1 Any boat intending to protest another boat under RRS 60.1(a) shall notify (sail numbers of boats involved, type of incident) a RC Member stationed on the starboard side of the RC finish boat promptly after finishing that race. This modifies RRS 61.
- 17.2 Protests shall be made in writing and delivered to the Jury at the Florida Yacht Club Fleet Center within one (1) hour after the time the Race Committee returns to the dock after the last race of the day. This changes RRS 61.3 and 62.2 The Protest Forms are available at Florida Yacht Club Fleet Center.
- 17.3 Within the protest time, the Race Committee shall post the sail numbers of all the boats that are disqualified, or penalized, under RRS 29 and 30 . A boat so notified may only file a request for a redress hearing within one (1) hour of that posting. This changes RRS 62.2.
- 17.4 A notice fulfilling the requirements of rule RRS 63.2, and indicating the parties, time and order of hearings will be posted not later than 30 minutes following the expiration of protest time limit.
- 17.5 On the last day of the regatta, a request for reopening a hearing shall be delivered:
  - (a) within the protest time limit if the party requesting reopening was informed of the decision on the previous day
  - (b) No later than thirty (30) minutes after the party requesting reopening was informed of the decision on that day.

This modifies rule RRS 66.

- 17.6 Breaches of SI 22 (Disposal of Refuse) shall not be grounds for protest by a boat. This changes RRS 60.1(a).

**Scoring:**

- 18.1 The regatta shall be scored using RRS Appendix A Low Point System. RRS A2 is modified so that no race scores will be excluded.
- 18.2 A boat awarded a TLE as described in 15.3 above shall receive a score equal to the number of finishers in that race plus 2. This changes RRS A4.2, ROC 15.
- 18.3 A boat intending to retire and be scored "RAF" shall report its intent in writing to the Jury

**Penalties:**

- 19.1 Any competitor using a One-Turn or a Two-Turns penalty pursuant to RRS 44.1 shall report that use (sail numbers of boats involved, type of incident) to a RC Member stationed on the starboard side of the RC finish boat promptly upon finishing that race.

**Team Racing:**

- 20.1 The use of team racing tactics shall not be tolerated. If the Race Committee (acting under RRS 32.1(e)) or Protest Committee determines that the use of team racing tactics may have significantly influenced the outcome of a race they shall order that race abandoned and, if possible, re-sailed excluding the participation of the infringing boat(s). This modifies RRS 36. If the race is not re-sailed the infringing boat(s) shall be subject to protest and disqualification.

**Disclaimer of Liability**

- 21.1 Competitors participate in the regatta entirely at their own risk. See RRS 4, Decision to Race. The organizing authority will not accept any liability for material damage, or personal injury, or death sustained in conjunction with, prior to, during, or after the regatta.

**Disposal of Refuse:**

- 22.1 The discharge of refuse into the water is prohibited during the entirety of this event. Any boat observed to be in violation is subject to protest and shall be assessed an infraction by the jury.

**Prizes:**

- 23.1 Prizes shall be awarded to the skipper and crew for the top THREE (3) places.
- 23.2 The US Women's Nationals Trophy shall be awarded to the highest finishing team who meets the requirements of the Deed of Gift.
- 23.3 The first place team will qualify as the SCIRA North American SCIRA Nation's Women's team to the 2010 Western hemisphere and Orient Championship.

**Signatures:**

\_\_\_\_\_  
John Fox - Race Committee Chairman

\_\_\_\_\_  
Don Hackbarth- SCIRA Representative